

# Memory Module Specifications

## KHX1800C9D3T1FK3/6GX

6GB (2GB 256M x 64-Bit x 3 pcs.) DDR3-1800MHz  
CL9 240-Pin DIMM Kit w/ Fan

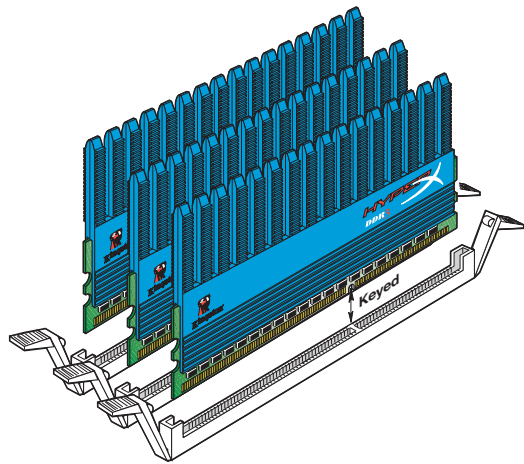

### DESCRIPTION

Kingston's KHX1800C9D3T1FK3/6GX is a kit of three 256M x 64-bit 2GB (2048MB) DDR3-1800MHz CL9 SDRAM (Synchronous DRAM) memory modules, based on sixteen 128M x 8-bit DDR3 FBGA components per module. Each module kit supports Intel® XMP (Extreme Memory Profiles). Total kit capacity is 6GB. Each module kit has been tested to run at DDR3-1800MHz at a low latency timing of 9-9-9-27 at 1.65V. The SPDs are programmed to JEDEC standard latency DDR3-1333MHz timing of 9-9-9 at 1.5V. Each 240-pin DIMM uses gold contact fingers and requires +1.5V. The JEDEC standard electrical and mechanical specifications are as follows:

This special kit part number includes Kingston's HyperX high-performance cooling fan assembly (KHX-FAN).

### SPECIFICATIONS

CL(IDD)	9 cycles
Row Cycle Time (tRCmin)	49.5ns (min.)
Refresh to Active/Refresh Command Time (tRFCmin)	110ns
Row Active Time (tRASmin)	36ns (min.)
Power	1.800 W (operating per module)
UL Rating	94 V - 0
Operating Temperature	0° C to 85° C
Storage Temperature	-55° C to +100° C

### FEATURES

- JEDEC standard 1.5V ± 0.075V Power Supply
- VDDQ = 1.5V ± 0.075V
- 667MHz fCK for 1333Mb/sec/pin
- 8 independent internal bank
- Programmable CAS Latency: 5,6,7,8,9,10
- Posted CAS
- Programmable Additive Latency: 0, CL - 2, or CL - 1 clock
- Programmable CAS Write Latency(CWL) = 7(DDR3-1333)
- 8-bit pre-fetch
- Burst Length: 8 (Interleave without any limit, sequential with starting address "000" only), 4 with tCCD = 4 which does not allow seamless read or write [either on the fly using A12 or MRS]
- Bi-directional Differential Data Strobe
- Internal(self) calibration : Internal self calibration through ZQ pin (RZQ : 240 ohm ± 1%)
- On Die Termination using ODT pin
- Average Refresh Period 7.8us at lower than TCASE 85°C, 3.9us at 85°C < TCASE ≤ 95°C
- Asynchronous Reset
- PCB : Height 2.401" (61.00mm) w/ heatsink, double sided component

Continued >>

**MODULE DIMENSIONS:**

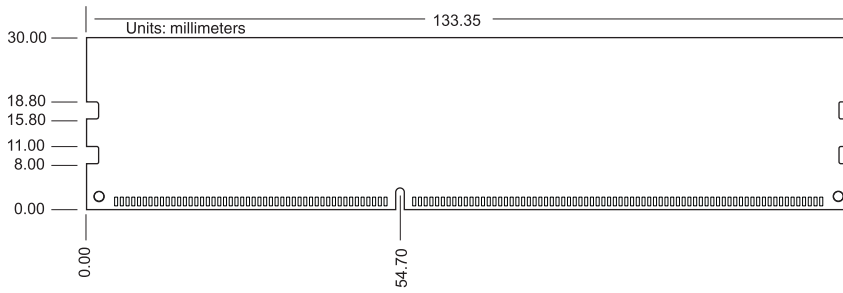
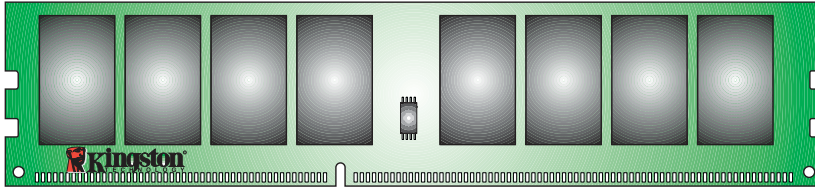
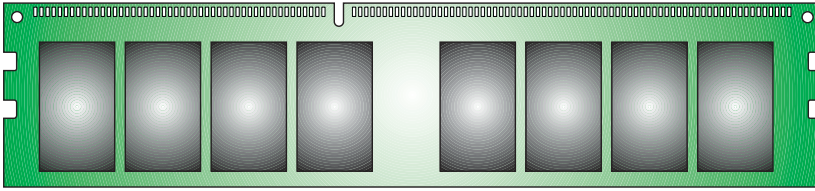

**MODULE WITH HEAT SPREADER:**

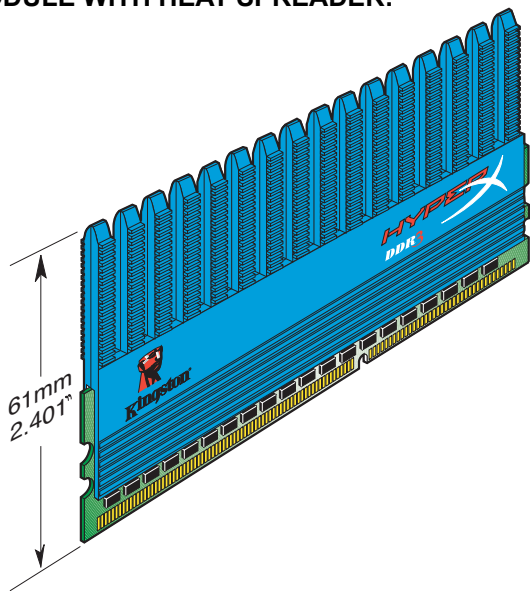

## KHX-FAN

### HyperX Cooling Fan Assembly

#### DESCRIPTION

This document describes Kingston's HyperX memory module cooling fan assembly. If you are looking to maximize the performance potential of your HyperX memory... this is it. With twin fans focusing air directly onto your HyperX modules, your modules will run cooler, even in the most demanding environments. The mechanical and electrical specifications are as follows:

#### SPECIFICATIONS

Rated Voltage	12 VDC
Operational Voltage	8 - 13.5 VDC
Input Current	0.09 amp
Input Power	1.08 watt
RPM	3000 $\pm$ 10%
Speed Control Type	
Signal Output	Frequency Generator (FG)
Max. Air Flow At Zero Static Pressure	0.43 m <sup>3</sup> /min 15.02 CFM
Max. Air Pressure At Zero Flow	2.31 mm-H <sub>2</sub> O 0.09 inch-H <sub>2</sub> O
Accoustical Noise	25 (28 max.) dB-A

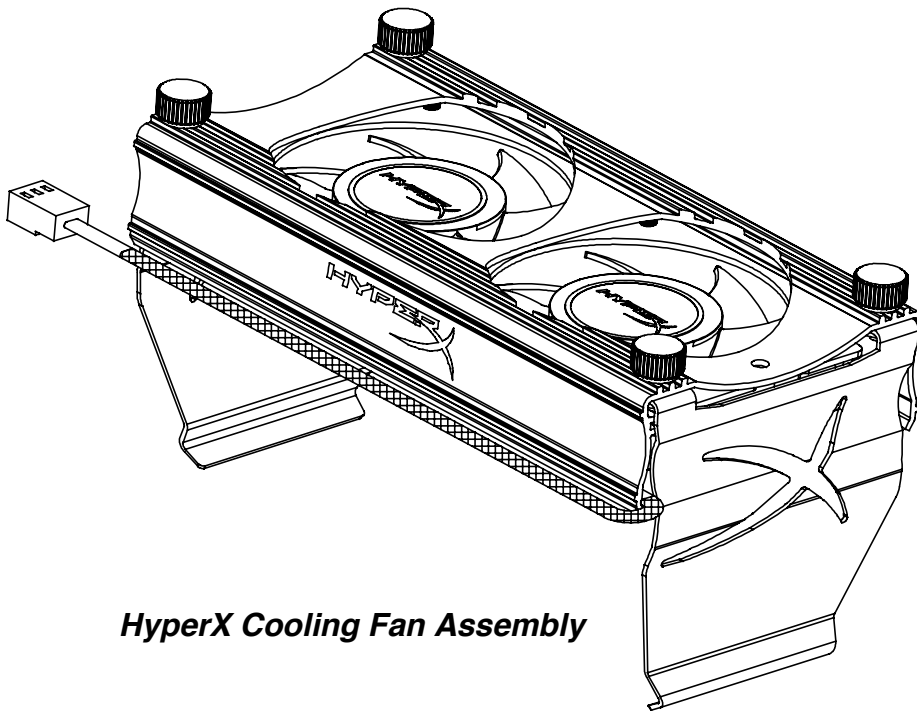

**HyperX Cooling Fan Assembly**

Continued >>

**ASSEMBLY:**

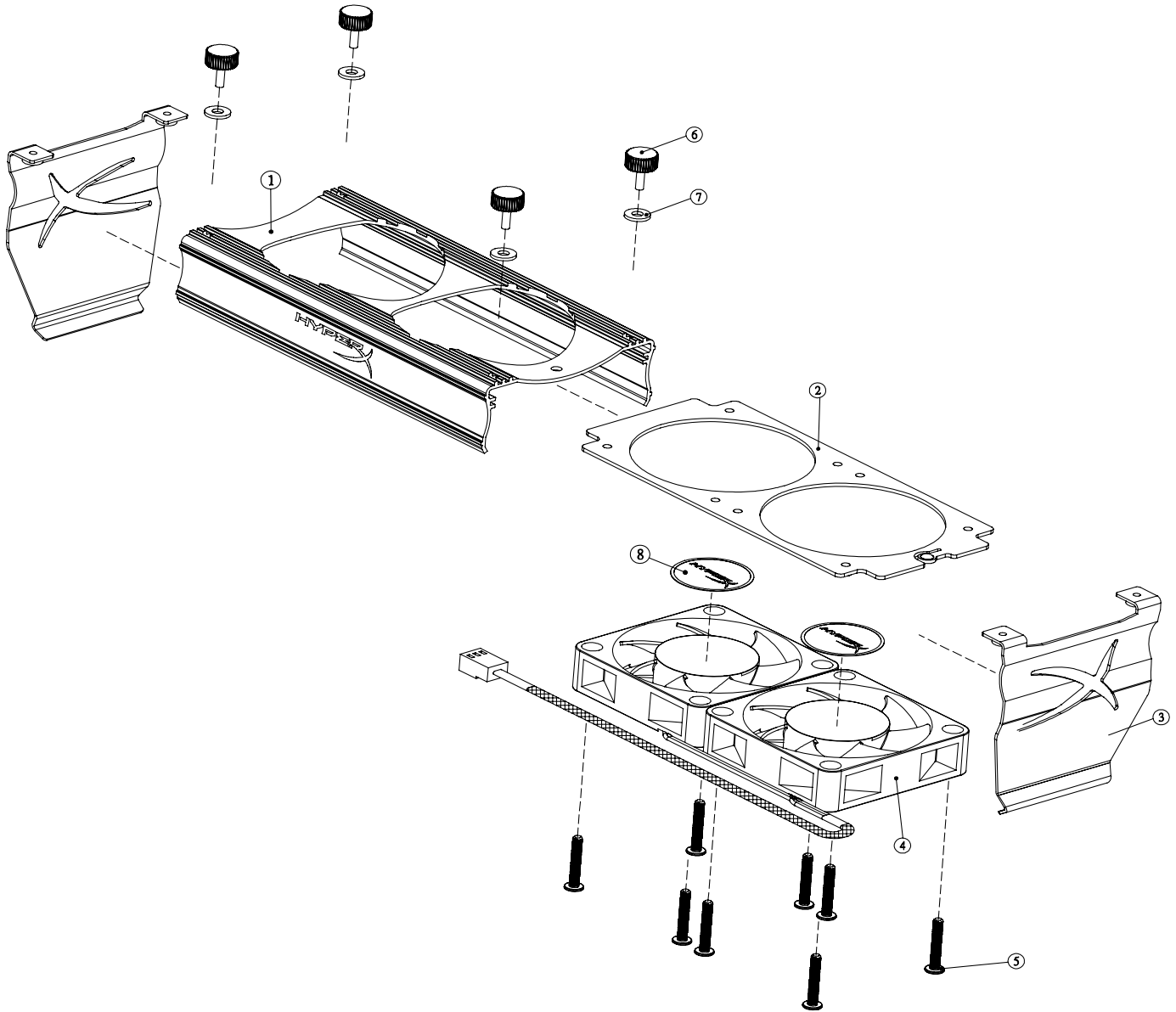

Continued >>

**DIMENSIONS:**

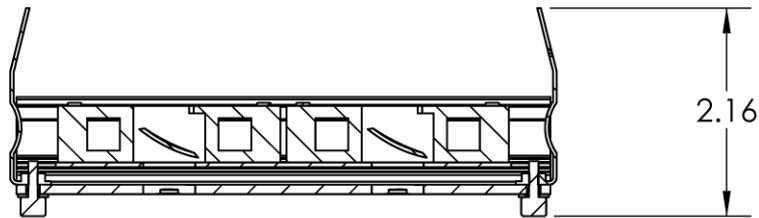
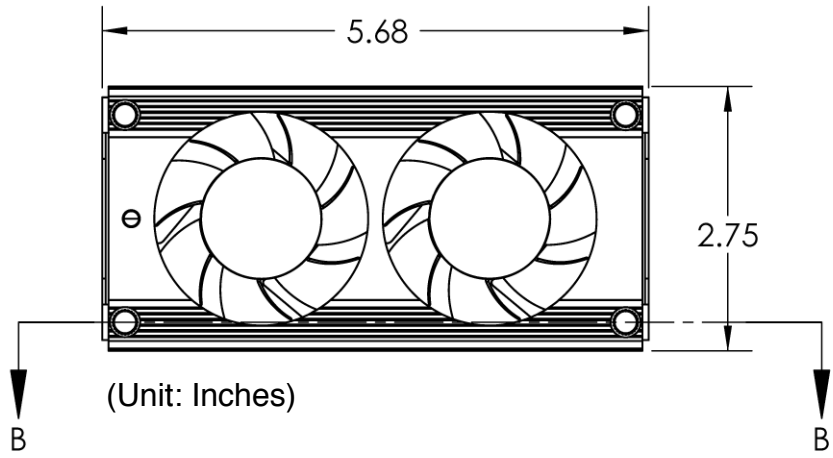

Continued >>

### INSTALLATION:

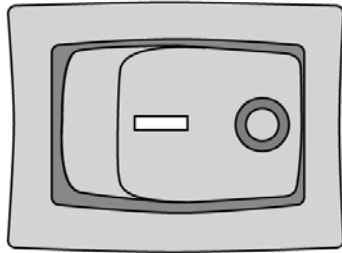

**Step #1:**  
Power the computer system off, disconnect the AC power cord and remove the computer cover.

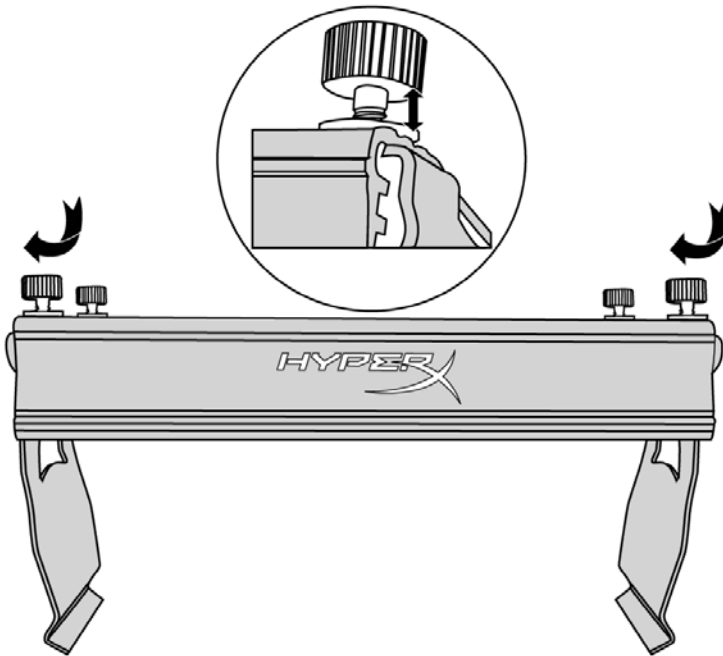

**Step #2:**  
To assemble the HyperX fan, secure the two side brackets with the four thumb screws / washers. Do not tighten the screws completely!

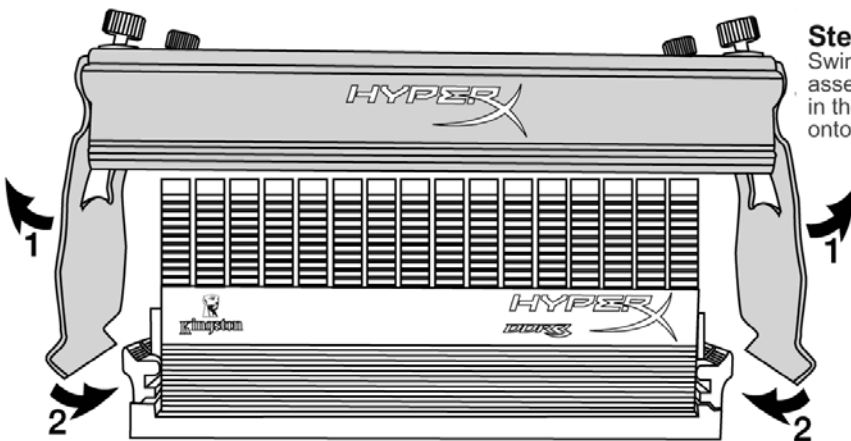

**Step #3:**  
Swing the retaining brackets open and slide the assembly over the HyperX modules as shown in the illustration. Rest the base of the brackets onto the memory socket lock tabs.

### INSTALLATION (cont.):

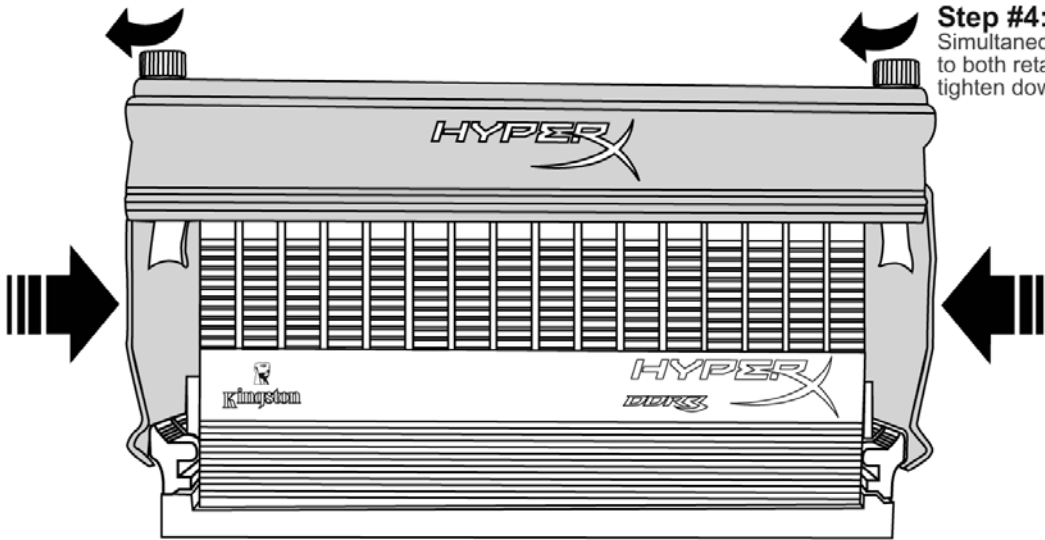

**Step #4:**  
Simultaneously apply pressure to both retaining brackets and tighten down all four thumb screws.

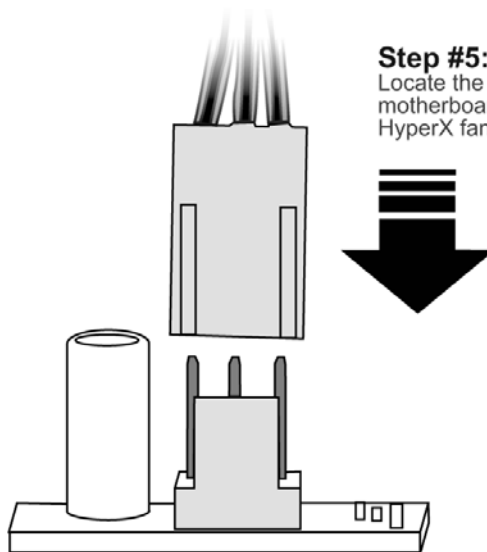

**Step #5:**  
Locate the fan power source on the motherboard and connect the HyperX fan power cable.

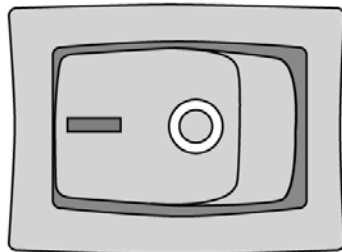

**Step #6:**  
Reconnect the AC power cord and power up the computer to verify fan operation. Replace the computer cover.

FOR MORE INFORMATION, GO TO [WWW.KINGSTON.COM](http://WWW.KINGSTON.COM)

All Kingston products are tested to meet our published specifications. Some motherboards or system configurations may not operate at the published HyperX memory speeds and timing settings. Kingston does not recommend that any user attempt to run their computers faster than the published speed. Overclocking or modifying your system timing may result in damage to computer components.