

KHX4000LL/512

512MB 64M x 64-Bit PC4000

CL3 184-Pin DIMM

DESCRIPTION:

This document describes Kingston's 64M x 64-bit (512MB) PC4000 SDRAM (Synchronous DRAM) CL3 memory module. The components on this module include eight 64M x 8-bit (16M x 8-bit x 4 Bank) DDR400 SDRAM in TSOP packages. This module has been tested to run at DDR 500MHz low latency timing of 3-3-3-8-1T at 2.7V. The SPD is programmed to JEDEC standard latency 400Mhz timing of 3-3-3-8-1T at 2.6V. This 184-pin DIMM uses gold contact fingers and requires +2.6V. The electrical and mechanical specifications are as follows:

FEATURES:

- ✓ Power supply : Vdd: 2.6V ± 0.1V, Vddq: 2.6V ± 0.1V
- ✓ Double-data-rate architecture; two data transfers per clock cycle
- ✓ Bidirectional data strobe(DQS)
- ✓ Differential clock inputs(CK and CK)
- ✓ DLL aligns DQ and DQS transition with CK transition
- ✓ Programmable Read latency 3 (clock)
- ✓ Programmable Burst length (2, 4, 8)
- ✓ Programmable Burst type (sequential & interleave)
- ✓ Timing Reference: 400MHz 3-3-3-8-1T at +2.6V / 500MHz 3-3-3-8-1T at +2.7V
- ✓ Edge aligned data output, center aligned data input
- ✓ Auto & Self refresh, 7.8us refresh interval (8K/64ms refresh)
- ✓ Serial presence detect with EEPROM
- ✓ High Performance Heat Spreader
- ✓ PCB : Height 1.250" (31.75mm), single sided component

PERFORMANCE:

- | | |
|---------------------------------|-------------------------------|
| ✓ Clock Cycle Time (tCK) | 5ns (min.) / 10ns (max.) |
| ✓ Row Cycle Time (tRC) | 55ns (min.) |
| ✓ Refresh Row Cycle Time (tRFC) | 70ns (min.) |
| ✓ Row Active Time (tRAS) | 40ns (min.) / 70,000ns (max.) |
| ✓ Power | 3.432 W (operating) |
| ✓ UL Rating | 94 V - 0 |
| ✓ Operating Temperature | 0° C to 70° C |
| ✓ Storage Temperature | -55° C to +150° C |

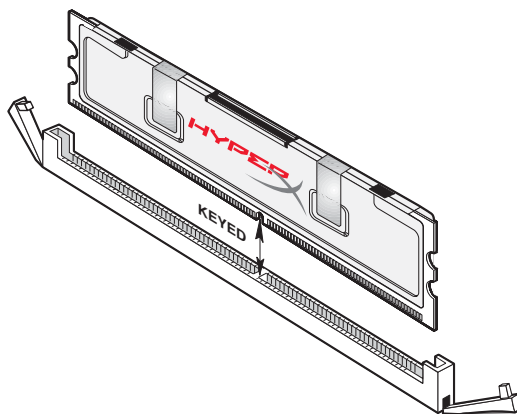

MODULE DIMENSIONS:

Units : Inches (Millimeters)

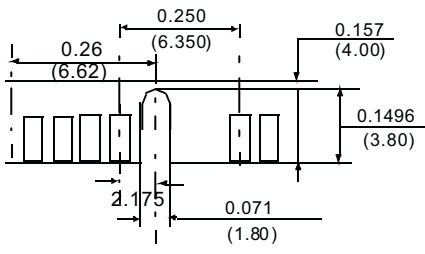
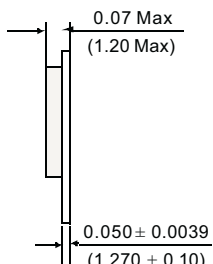
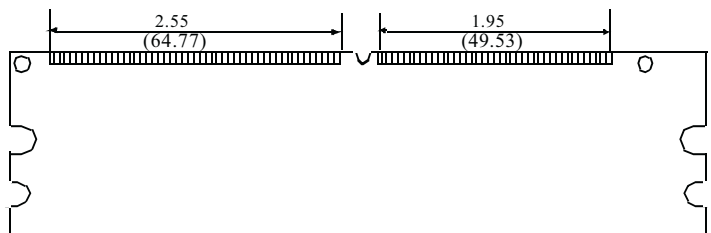
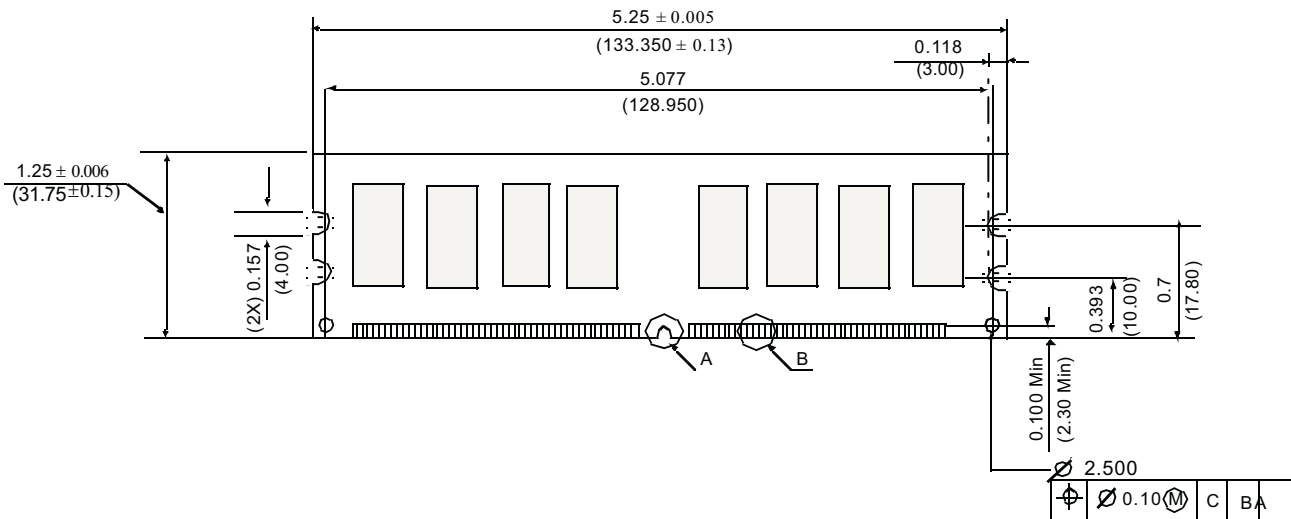

Detail A

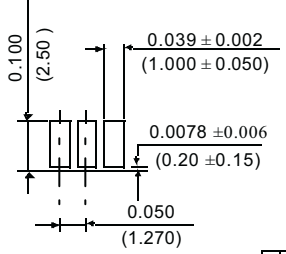

Detail B

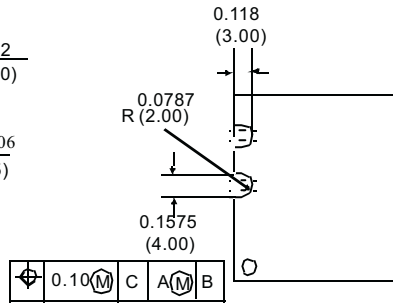

Tolerances : ± 0.005(.13) unless otherwise specified.

For more information, go to www.kingston.com

All Kingston products are tested to meet our published specifications. Some motherboards or system configurations may not operate at the published HyperX memory speeds and timing settings. Kingston does not recommend that any user attempt to run their computers faster than the published speed. Overclocking or modifying your system timing may result in damage to computer components.